

## ALFA43X

CONVECTION OVEN - 1.5 AMP

4 Trays 435x320mm



### GUARANTEED COOKING PERFORMANCE

Smeg catering products draw on the experience of approximately 40 years in the Foodservice industry. The ovens are built with the highest quality materials, making them particularly tough and strong.

### VERSATILITY

The complete Smeg Foodservice catalogue offers a range of ovens for all needs and environments, fulfilling any requirement in the most efficient and high-performing way.

### PRODUCT FEATURES

- Compact and functional design, robust stainless steel construction
- Enamelled oven cavity
- Manual electromechanical controls, extremely simple and reliable
- **Excellent baking uniformity across all trays, perfect heat distribution in all conditions of use**
- Excellent internal visibility, due to the large glass and powerful inner light
- Double glass door, with internal glass removable for cleaning
- 4 flat aluminium trays (model 3820) included
- **15A plug**
- Dimensions (mm) (WxDxH): 602x584x537
- **24 months parts and labour warranty**

### 4 X FLAT ALUMINIUM TRAYS (INCLUDED)



### ACCESSORIES

- TVL40 - Stainless steel stand
- 3820 - Aluminized steel tray
- 3729 - Chrome grid
- 3780 - Non-stick tray
- 3735 - Undulated chrome grid
- 3755 - Flat aluminium tray with holes

# ALFA43X

CONVECTION OVEN - 1.5 AMP

4 Trays 435x320mm

## TECHNICAL SPECIFICATIONS

|                                      |                         |
|--------------------------------------|-------------------------|
| Dimensions (mm) (WxDxH)              | 602x584x537             |
| Trays (mm)                           | 435x320                 |
| Tray capacity                        | 4                       |
| Distance between trays (mm)          | 80                      |
| Control type                         | Manual                  |
| Door/hood structure                  | Stainless steel         |
| Temperature range (°C)               | 50 - 250°C              |
| Timer                                | 1 - 60min + manual      |
| Power rating & electrical connection | 230V~/13A/3.0kW/50-60Hz |

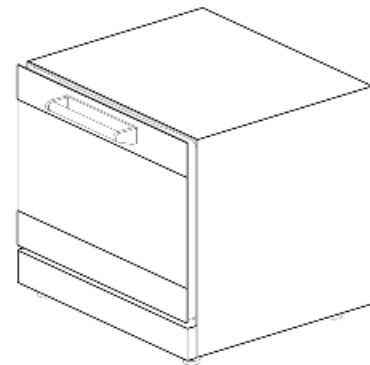
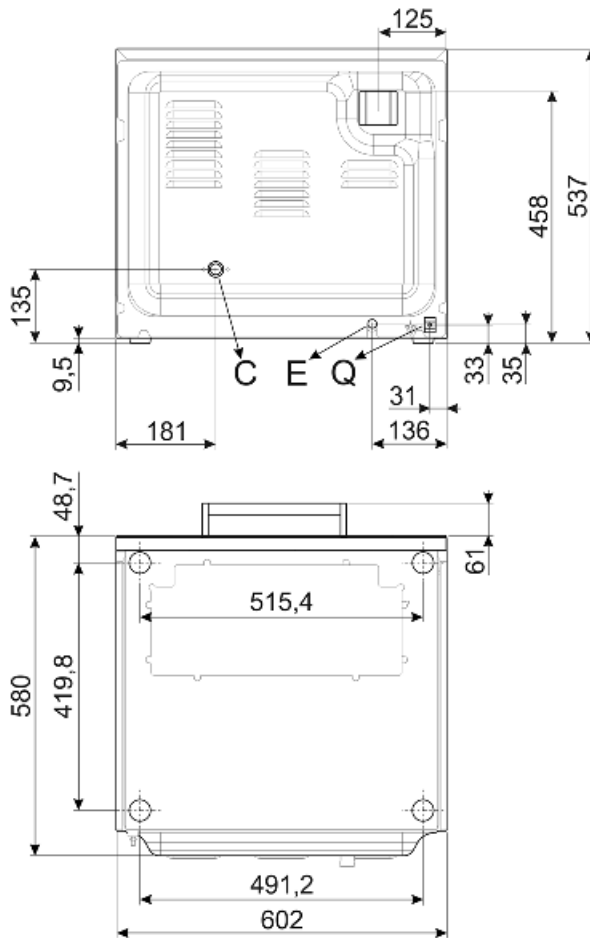

|   |  |
|---|--|
| Q | MORSETTO EQUIPOTENZIALE<br>EARTH TERMINAL                                    |
| E | CAVO ALIMENTAZIONE ELETTRICA<br>ELECTRICITY SUPPLY CABLE                     |
| C | TUBO DI CARICO (solo su alcuni modelli)<br>FILLER HOSE (or some models only) |



UNI EN ISO 9001  
9130-Smeg

UNI EN ISO 14001  
9191-SME2

DHSAS 18001  
9192-SME3