

HTYA615

FULLY INSULATED PASSTHROUGH DISHWASHER - 9.7KW THREE PHASE (7.0 KW SINGLE PHASE OPTIONAL)

Special line **500/600x500mm basket**



GUARANTEED WASH PERFORMANCE

In commercial dishwashers, the rinse is the most important part of the wash cycle, as it is the only one performed with clean water. This is the reason why, at Smeg, we believe all commercial dishwashers must have **a rinse pump on board**, the only way to guarantee that optimal and constant pressure and temperature are maintained throughout the rinse cycle.

WE BELIEVE IN OUR QUALITY

All dishwashers are manufactured in our state of the art factory in Italy, where we monitor all phases of design, engineering and production.

PRODUCT FEATURES

- **Double skin, fully insulated hood and panels**
- Construction in AISI 304 stainless steel
- Small capacity tank (25lt), moulded and with rounded edges
- Hood opening height: 420mm
- **Capacity to wash 600x500mm baskets and 600x400 trays**
- **HTR (High Temperature Rinse) system with atmospheric boiler and rinse pump**
- 3.2 litres water rinse cycle
- Drain pump
- Triple stage dynamic filtration system to separate dirt particles from wash water and to control tank level
- Water connection: from Cold to 60°C
- Upper and lower wash and rinse arms in AISI 304 stainless steel
- Full size tank filter with removable basket, all in AISI 304 stainless steel
- Electronic control with 6 wash programs
- Shortest wash program 60 seconds
- Automatic start on hood closure
- Soft start wash pump
- Automatic self-cleaning cycle and shut-off at the end of drain cycle
- Thermostop system to ensure correct rinse temperature
- Adjustable peristaltic pumps for detergent and rinse aid injection
- Self-diagnostic system with error messages
- **Power connection: three phase (standard) or single phase (optional)**
- **24 months parts and labour warranty**

INCLUDED ACCESSORIES

- Dish basket: 1 x PB60D01 (600x500x115mm)
- Cutlery basket: 1 x PHOOS03
- Flat basket: 1 x PB60G01 (600x500x115mm)

HTYA615

FULLY INSULATED PASSTHROUGH DISHWASHER - 9.7KW THREE PHASE (7.0 KW SINGLE PHASE OPTIONAL)

Special line **500/600x500mm basket**

TECHNICAL SPECIFICATIONS

Dimensions (mm) (WxDxH)

Note	Installation details and footprint remain the same as all previous corresponding CWC models
Basket (mm)	600x500 or 500x500
Shortest wash program	60 sec
Tank capacity (litres)	25
Boiler heating element (kW)	6.0 - 9.0
Power rating & electrical connection	Standard 400 V 3N~ / 16 A / 9,7 kW / 50 Hz Optional 230 V~ / 31 A / 7,0 kW / 50 Hz
Net weight	145kg

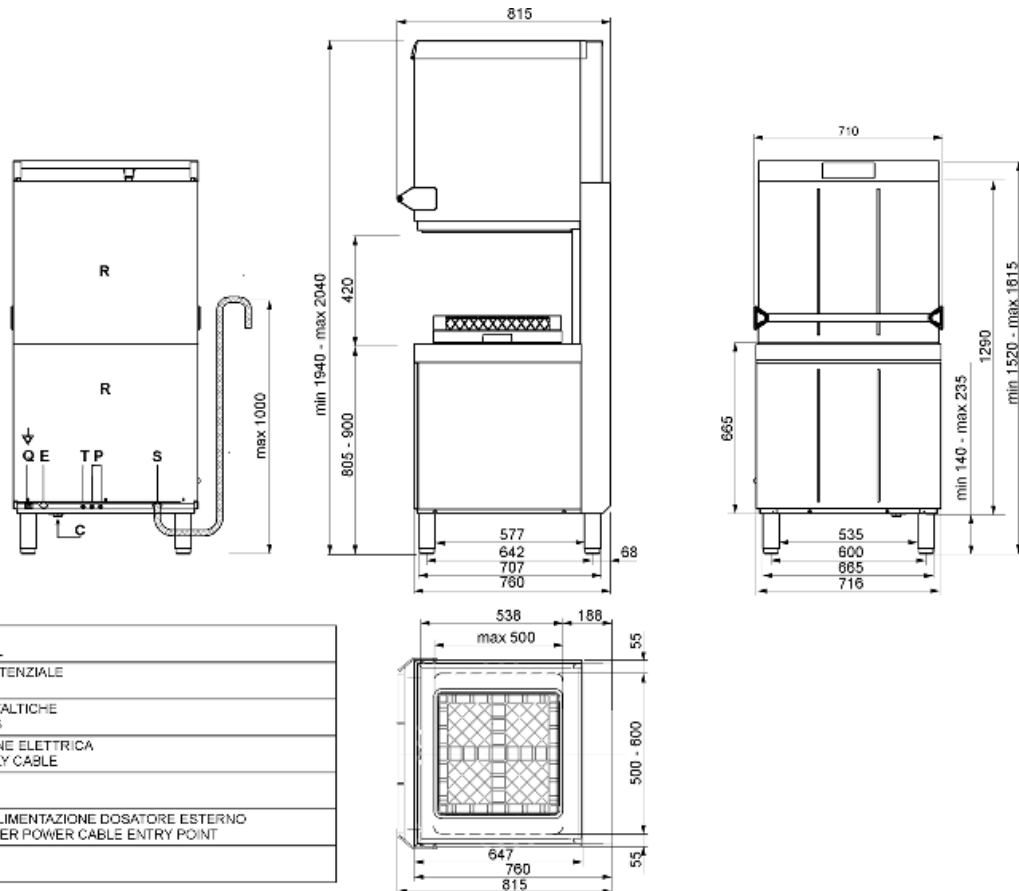

* Supplied water temperature >50°C and <60°C and three-phase electrical connection whenever possible.

* Indicative wash times

